

# WKA 2019 Tech Manual Addition – Push Back Fairing

## Kid Kart Class EXCLUDED

### 208.25 PUSH BACK NOSE/FAIRING, (Kid Kart Class EXCLUDED)

The front nose must be affixed to the kart with the CIK-stamped Front Fairing Mounting Kit, with the stamped arrow facing up. It must be possible for the front fairing to move freely back in the direction of the chassis without any obstruction from any part that may restrict movement. Any mechanical work or other intervention to maximize the friction of the front bumpers is strictly forbidden. There must be a clearance at all points between the front bumpers, (upper and lower tubes), and the front fairing of 25.4 mm, (1-inch), at all times.

The front fairing must be in the correct position at all times during competitive elements, (see CIK Technical drawings 2c and 2d). Should a driver or other person put back in place a front fairing that was not correctly positioned before the driver crosses the scales and reports to Tech, the driver will be disqualified from that competitive element.

#### DESSIN TECHNIQUE N°2c

Kit de montage de carénage avant

#### TECHNICAL DRAWING No. 2c

Front fairing mounting kit

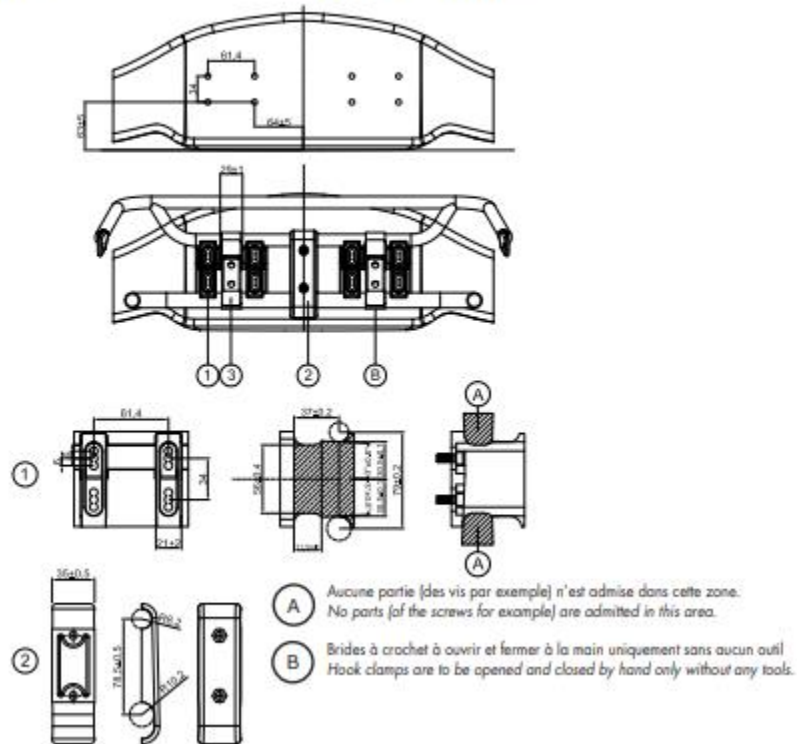

**DESSIN TECHNIQUE N° 2d**

**Installation correcte du «Carénage Avant»**

Position correcte / Correct position

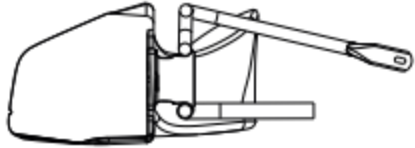

**TECHNICAL DRAWING No. 2d**

**Correct installation of the "Front Fairing"**

Position acceptable / Acceptable position

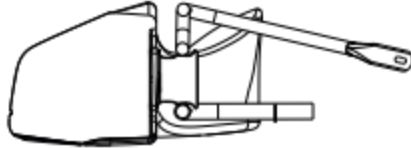

Position non acceptable si une quelconque partie des tubes du pare-chocs avant se trouve dans les zones marquées (A).

Not acceptable position if any part of the tubes of the front bumper are in the marked areas (A).

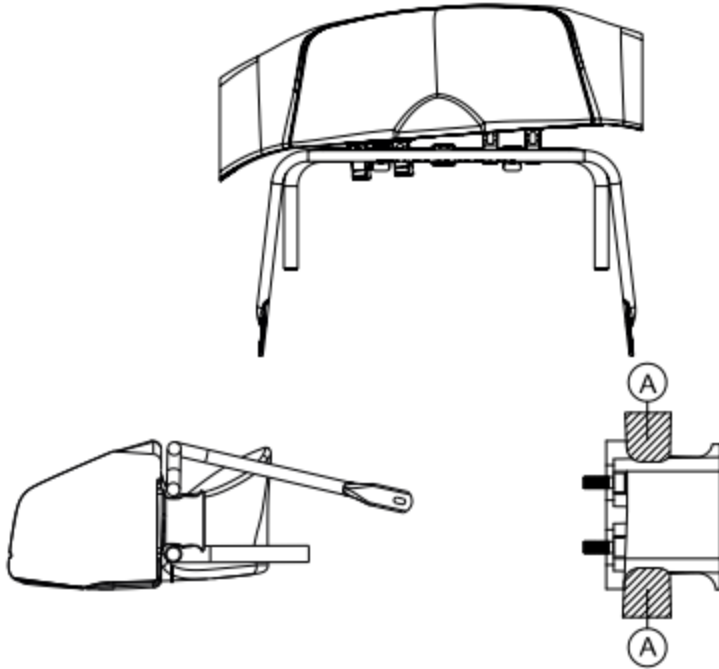

**208.25.1 PUSH BACK BUMPER/FAIRING PENALTY**

Front Fairings that are verified to be pushed back in the scales/tech areas will be penalized 2-positions from the results of the qualifying or race if only one side is pushed in, and 5-positions from the results of the qualifying or race if both sides are pushed in.

**208.25.2 PUSH BACK FAIRING PENALTY APPEAL**

For Qualifying, Heats, and Pre-Finals, push back fairing penalties cannot be appealed. For Finals, competitors that were penalized may (but is not mandatory), submit video from only their on-board video only relating to the incident(s) where the fairing was pushed back for only that final. As with all appeals, the appeal must be submitted within the required time restraints.